

9. DIRECT SCREWING INTO PLASTICS AND METAL

9.1 Direct screwing into plastics

The use of plastics is gaining in importance through new application possibilities.

Advantages here are found among other things in the fields of weight reduction, increased chemical resistance and in recycling components.

The direct screwing into plastics with thread-forming metal screws offers advantages over other connection methods through its economic assembly possibilities, the ability to be unscrewed and low-cost procurement. Fasteners constructed for screwing into plastics in particular enable greater process security in comparison to other screw types through their lower flank angle and greater thread pitch.

With its WÜPLAST® product line the Würth Industrie Service GmbH & Co. KG offers its customers an in-stock range of thread-forming metal screws for the application in plastics. Over 150 different dimensions are manufactured according to standards of the automotive industry.

Thread geometry 30° angle

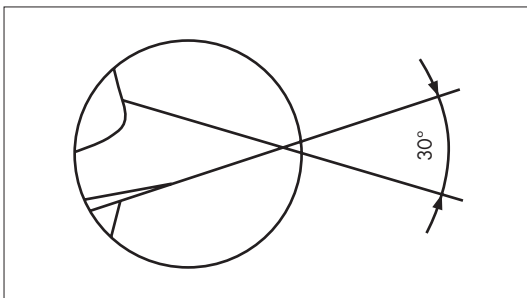

- Reduction of radial tensions
Construction of thinner walls, possibly savings of costs and weight
No damage to the screw dome
- Greater overlapping between the thread flanks and material greater pull-out forces increase the process security.

Optimised thread pitch

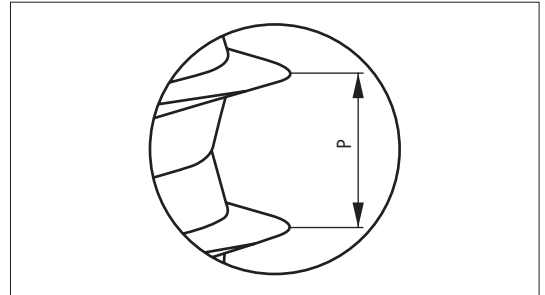

- Highly self-locking
Independent loosening of the connection is less likely
- Material protection
Greater loadability of the screw assembly

Optimised core diameter

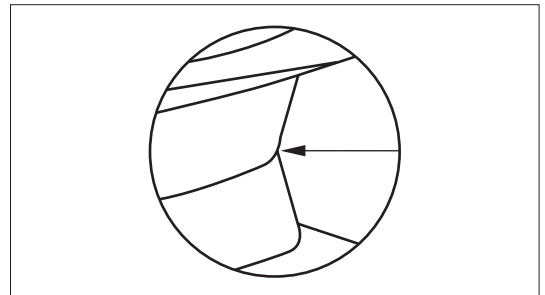

- No material jam/improved material flow
No damage to the material and therefore enhanced assembly security
- Lower tightening torques
Secure connection because of the greater difference between screwing torque and thread stripping torque

The reliable multiple connections of WÜPLAST® products is secured through the combination of these features.

Tube design:

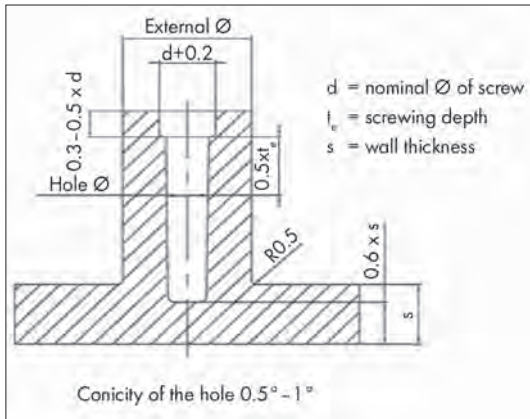

Construction:

The properties of WÜPLAST® screws enable the tube to be constructed with thin walls and flat.

Relief hole:

The relief hole at the upper end of the drilled hole reduces tension overlapping and thus prevents the tube from bursting.

At the same time it serves to guide the screw during assembly.

The tube geometry is to be adjusted to the different materials.

Material		Hole Ø mm	External Ø mm	Recommended screwing depth mm e
ABS	Acrylonitrile/butadiene/styrene	0.8x d	2x d	2x d
ASA	Acrylonitrile/styrene/acrylic ester	0.78x d	2x d	2x d
PA 4.6	Polyamide	0.73x d	1.85x d	1.8x d
PA 4.6-GF30	Polyamide	0.78x d	1.85x d	1.8x d
PA 6	Polyamide	0.75x d	1.85x d	1.7x d
PA 6-GF30	Polyamide	0.8x d	2x d	1.8x d
PA 6.6	Polyamide	0.75x d	1.85x d	1.7x d
PA 6.6-GF30	Polyamide	0.82x d	2x d	1.8x d
PA 30GV	Polyamide	0.8x d	1.8x d	1.7x d
PBT	Polybuteneterephthalate	0.75x d	1.85x d	1.7x d
PBT-GF30	Polybuteneterephthalate	0.8x d	1.8x d	1.7x d
PC	Polycarbonate	0.85x d	2.5x d	2.2x d*
PC-GF30	Polycarbonate	0.85x d	2.2x d	2.2x d*
PE (weich)	Polyethylene	0.7x d	2x d	2x d
PE (hart)	Polyethylene	0.75x d	1.8x d	1.8x d
PET	Polyethylene terephthalate	0.75x d	1.85x d	1.7x d
PET-GF30	Polyethylene terephthalate	0.8x d	1.8x d	1.7x d
PETP	Polyethylene terephthalate	0.75x d	1.85x d	1.7x d
PETP 30GV	Polyethylene terephthalate	0.8x d	1.8x d	1.7x d
PMMA	Polymethylmethacrylate	0.85x d	2x d	2x d
POM	Polyoxymethylene	0.75x d	1.95x d	2x d
PP	Polypropylene	0.7x d	2x d	2x d
PP-TV20	Polypropylene	0.72x d	2x d	2x d
PPO	Polyphenylenoxide	0.85x d	2.5x d	2.2x d**
PS	Polystyrene	0.8x d	2x d	2x d
PVC (hart)	Polyvinyl chloride	0.8x d	2x d	2x d
SAN	Styrene/acrylonitrile	0.77x d	2x d	1.9x d

* TnP test

** TnBP test materials sensitive to tension cracking

Assembly instructions

Schematic curve of the tightening process

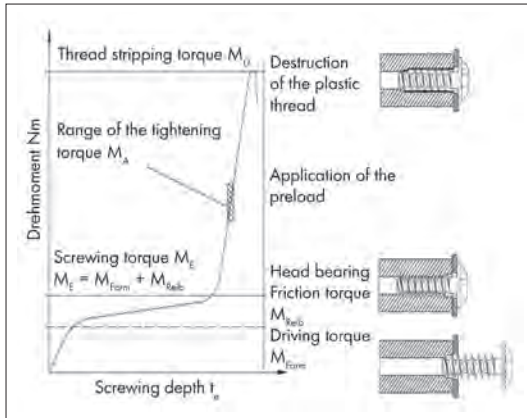

Tightening torque:

Necessary for a reliable screwed joint is a great difference between the screwing and the thread-stripping torques.

The required tightening torque can be determined theoretically with the following equation:

$$M_A = M_E + 1/3 \dots 1/2 (M_{\ddot{U}} - M_E)$$

The screwing and the thread-stripping torques are to be determined in experiments.

A secure directly screwed plastic joint can only be made with torque-controlled and rotation-angle controlled assembly equipment. The screwing speed is to be selected between 300 rpm and 800 rpm.

Because of the heat effect, greater speeds lead to damage to the plastic and to a disproportionate reduction of the preload force.

Both the tube design and the tightening torque are to be checked in practice on the components.

9.2 Direct screwing into metals

Thread forming screws for metals are grooving screws with metric threads and tapping screws. These screws groove the counterthread themselves without cutting. They can be used in ductile metals such as, e.g., steel, or in

lightweight construction materials up to 140 HV10 or in accordance with a tensile strength of 450 MPa.

9.2.1 Metric thread grooving screws

These screws are used in clearance holes and very frequently in tapping holes (aluminium or zinc diecasting).

The DIN 7500 screw is the oldest and most widespread design here and defines the thread and the technical delivery conditions. However, screws such as Taptite, Duo-Taptite or Taptite 2000 are frequently found on the market today.

When driven in, the screws form a normal nut thread without cutting into which a conventional screw can be screwed.

These screws are usually case-hardened, which means that the surface is extremely hard and the core is very ductile.

To make thread grooving easier the screw cross-sections are specially formed (trilobular) over the whole length or at the screw end only.

For placing in the core removing hole the screw thread is conical over max. $4 \times P$ thread pitch in accordance with DIN 7500.

The thread pitch, which is smaller in comparison with tapping screws, and the high thread engagement give the screws a certain amount of security against independent loosening.

9.2.2 Screw assemblies for thread-grooving screws in accordance with DIN 7500 (Gefu-1 and Gefu-2)

The ideal drilling diameter for the tapping holes is to be determined through experiments. The following two tables provide good points of reference.

Gefu-1: Recommended tapping holes for cold malleable materials in dependence on the screwing length

Thread d	M3			M4			M5			M6		
Material thickness of the screwing length	Recommended tolerance field											
	St	Al	Cu	St	Al	Cu	St	Al	Cu	St	Al	Cu
1.0		2.7										
1.2		2.7										
1.5		2.7			3.6			4.5				
1.6		2.7			3.6			4.5				
1.7		2.7			3.6			4.5				
1.8	2.75	2.7			3.6			4.5				
2.0	2.75	2.7	2.7		3.6			4.5			5.4	
2.2		2.75			3.6			4.5			5.4	
2.5		2.75		3.65	3.6	3.6		4.5			5.4	
3.0		2.75		3.65	3.6	3.6		4.5			5.45	
3.2		2.75		3.65	3.6	3.6	4.55	4.5	4.5		5.45	
3.5		2.75			3.6			4.55			5.45	
4.0		2.75			3.6			4.55		5.5	5.45	5.45
5.0		2.75		3.7	3.65	3.65		4.6		5.5	5.45	5.45
5.5		2.75		3.7	3.65	3.65		4.6			5.5	
6.0		2.75		3.7	3.65	3.65		4.6			5.5	
6.3		2.75						4.65			5.5	
6.5		2.75						4.65			5.5	
7.0		2.75						4.65		5.55	5.5	5.5
7.5								4.65		5.55	5.5	5.5
8 to ≤ 10								4.65			5.55	
>10 to ≤ 12												
>12 to ≤ 15												

Gefu-2: Recommended tapping holes for ductile materials

Thread d	M5			M6			M8		
Material thickness of the screwing length	Recommended tolerance field								
	St	Al	Cu	St	Al	Cu	St	Al	Cu
1.0									
1.2									
1.5	4.5	4.5	4.5						
1.6	4.5	4.5	4.5						
1.7	4.5	4.5	4.5						
1.8	4.5	4.5	4.5						
2.0	4.5	4.5	4.5	5.4	5.4	5.4			
2.2	4.5	4.5	4.5	5.4	5.4	5.4	7.25	7.25	7.25
2.5	4.5	4.5	4.5	5.4	5.4	5.4	7.25	7.25	7.25
3.0	4.5	4.5	4.5	5.45	5.45	5.45	7.25	7.25	7.25
3.2	4.55	4.5	4.5	5.45	5.45	5.45	7.25	7.25	7.25
3.5	4.55	4.55	4.55	5.45	5.45	5.45	7.25	7.25	7.25

Thread d	M5			M6			M8		
Material thickness of the screwing length	Recommended tolerance field								
	St	Al	Cu	St	Al	Cu	St	Al	Cu
4.0	4.55	4.55	4.55	5.5	5.45	5.45	7.3	7.3	7.3
5.0	4.6	4.6	4.6	5.5	5.45	5.45	7.4	7.3	7.3
5.5	4.6	4.6	4.6	5.5	5.5	5.5	7.4	7.3	7.3
6.0	4.6	4.6	4.6	5.5	5.5	5.5	7.4	7.3	7.3
6.3	4.65	4.65	4.65	5.5	5.5	5.5	7.4	7.35	7.35
6.5	4.65	4.65	4.65	5.5	5.5	5.5	7.4	7.35	7.35
7.0	4.65	4.65	4.65	5.55	5.5	5.5	7.5	7.4	7.4
7.5	4.65	4.65	4.65	5.55	5.5	5.5	7.5	7.4	7.4
8 to <= 10	4.65	4.65	4.65	5.55	5.55	5.55	7.5	7.4	7.4
>10 to <=12							7.5	7.5	7.5
>12 to <=15							7.5	7.5	7.5

9.2.3 Direct screwing into metals with thread-grooving screws in accordance with DIN 7500

When they are driven in, DIN 7500 screws form their own counterthread without cutting through plastic deformation of the base material (steel, HB max. 135, light metal, nonferrous heavy metal). A2 screws can normally only be driven into lightweight metal.

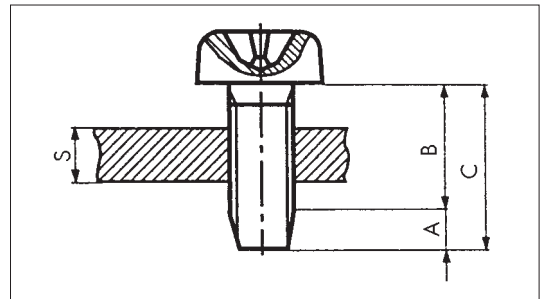

Strength properties, tapping hole geometry

When the screw length is selected, the length of the non-bearing conical screw end has to be taken into account! With harder materials the hole diameters are to be determined in experiments.

- A = Max. 4 P
- B = Possible bearing thread length
- C = Total length, tolerance js 16
- s = Material thickness

Fig. AB

Technical data	Thread nominal diameter							
	M2	M2.5	M3	M3.5	M4	M5	M6	M8
Thread pitch P [mm]	0.4	0.45	0.5	0.6	0.7	0.8	1	1.25
Tightening torque max.	approx. 80% of the fracture torque							
Fracture torque min. [Nm]	0.5	1	1.5	2.3	3.4	7.1	12	29
Tensile force min. [kN]	1.7	2.7	4	5.4	7	11.4	16	29
Material strength s [mm]	Tapping hole diameter d – H11 for steel. HB max. 135; drilled and stamped							
2 and less	1.8	2.25	2.7	3.15	3.6	4.5	5.4	7.25
4.0	1.85	2.3	2.75	3.2	3.65	4.5	5.45	7.3
6.0		2.35	2.8	3.25	3.7	4.6	5.5	7.35
8.0				3.3	3.75	4.65	5.55	7.4
10.0						4.7	5.6	7.45
12.0							5.65	7.5
14.0								7.5
16.0								7.55

Tapping holes for diecasting

All recommendations must be checked by means of practical assembly experiments.

General

t_1 [mm]: Upper hole range, with increased conicity for roundings advantageous for casting, strengthening of the mandrel, screw centring, prevention of material bucking, and adaptation to low-cost standard screw lengths.

t_2/t_3 [mm]: Bearing tapping hole range, max. tightening angle 1°

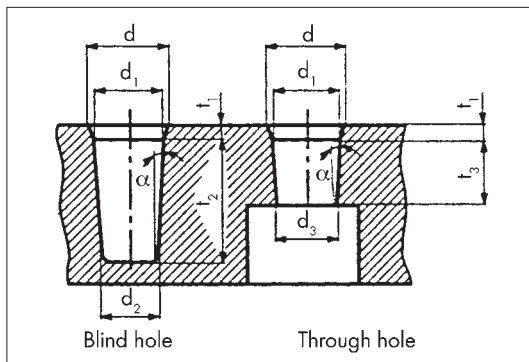

Fig. AC

Thread nominal diameter	M2.5	M3	M3.5	M4	M5	M6	M8
dH12 [mm]	2.7	3.2	3.7	4.3	5.3	6.4	8.4
d_1 [mm]	2.36	2.86	3.32	3.78	4.77	5.69	7.63
d_2 [mm]	2.2	2.67	3.11	3.54	4.5	5.37	7.24
d_3 [mm]	2.27	2.76	3.23	3.64	4.6	5.48	7.35
Tolerances for d_1, d_2, d_3 in [mm]	+0 -0.06	+0 -0.06	+0 -0.075	+0 -0.075	+0 -0.075	+0 -0.075	+0 -0.09
t_1 [mm]	Variable, minimum 1x thread pitch P						
t_2 [mm]	5.3	6	6.9	7.8	9.2	11	14
Tolerances for t_2 in [mm]	+0.2 -0.0	+0.2 -0.0	+0.6 -0.0	+0.5 -0.0	+0.5 -0.0	+0.5 -0.0	+0.5 -0.0
t_3 [mm]	2.5	3	3.5	4	5	6	8

9.3 Tapping screws

9.3.1 Tapping screw assemblies

The following examples for screw assemblies apply for tapping screws with threads in accordance to DIN EN ISO 1478. Tapping screws with form C with a point (also known as a pilot point) are used preferably. This applies in particular when several plates are screwed together and hole misalignment must be expected.

Minimum value for the total thickness of the plates to be screwed together

The plate thicknesses of the parts that are to be screwed together must be greater than the increase in the thread of the selected screw, because otherwise sufficient tightening torque cannot be applied because of the thread run-out under the screw head. If this condition is fulfilled, tapping screw assemblies as shown in Figs. 3 to 6 can be used.

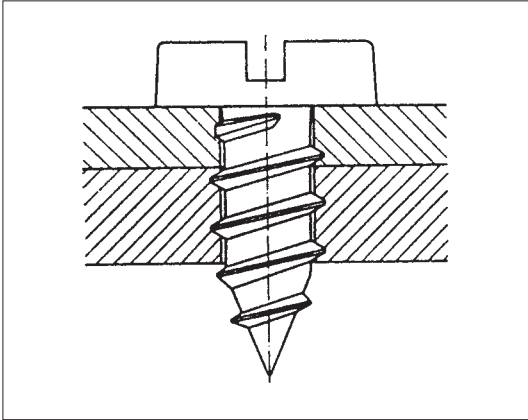

Fig. 1: Simple screwed joint (two tapping holes)

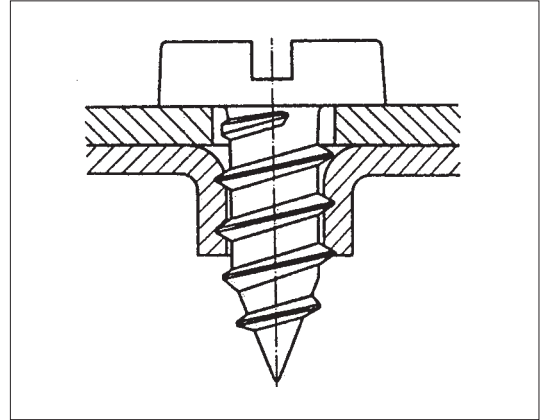

Fig. 4: Tapping hole drawn through (thin plates)

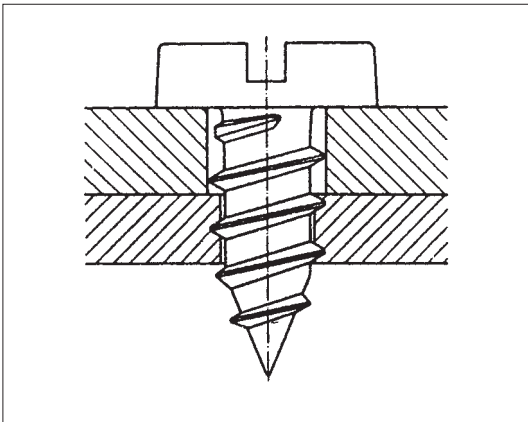

Fig. 2: Simple screwed joint with through hole

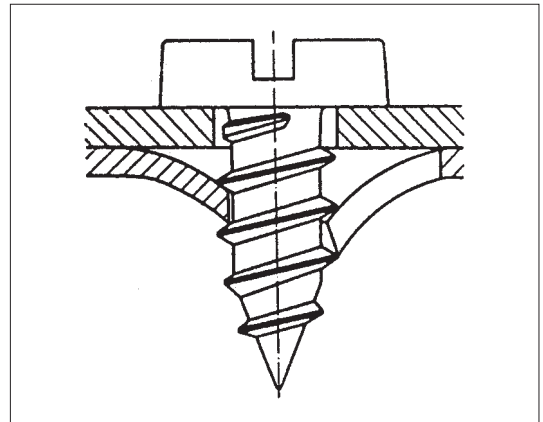

Fig. 5: Prestole screwed joint

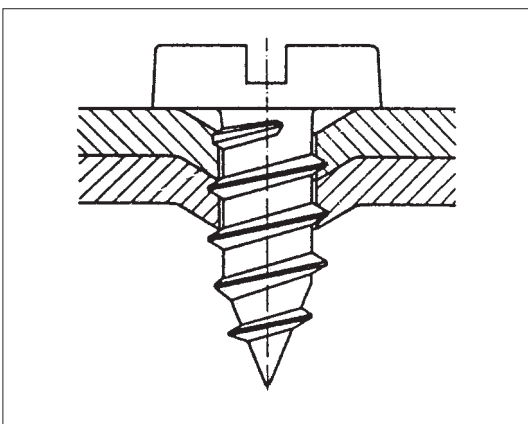

Fig. 3: Tapping hole, widened (thin plates)

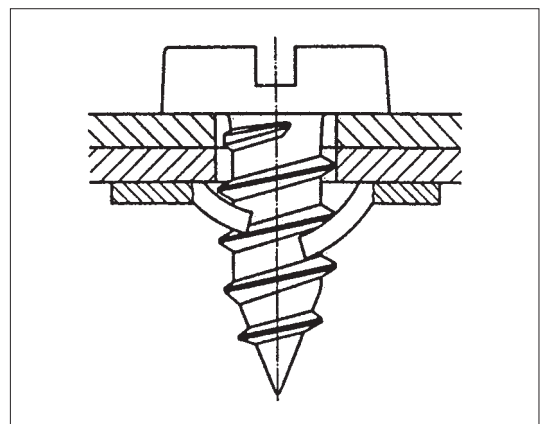

Fig. 6: Screwed joint with tightening nut

Tapping hole diameters

The tapping hole diameters shown in the following tables apply subject to the following preconditions:

- Simple tapping screw assembly in accordance with Fig. Z
- Tapping hole drilled
- Tapping screw case-hardened and uncoated
- Screwing torque $\leq 0.5 \times$ minimum fracture torque
- Screwed joint in direction of stamping only
- Select stamped holes possibly 0.1 – 0.3 mm larger

Internal preliminary tests should be carried out with other screws or plate materials.

Reference values for the tapping hole diameter

Plate thickness s	Tapping hole diameter d_b for thread size ST 2.2									
	Material strength R_m N/mm ²									
	100	150	200	250	300	350	400	450	500	
0.8	1.7	1.7	1.7	1.7	1.7	1.7	1.7	1.7	1.7	1.7
0.9	1.7	1.7	1.7	1.7	1.7	1.7	1.7	1.7	1.7	1.7
1.0	1.7	1.7	1.7	1.7	1.7	1.7	1.7	1.7	1.8	1.8
1.1	1.7	1.7	1.7	1.7	1.7	1.7	1.7	1.8	1.8	1.8
1.2	1.7	1.7	1.7	1.7	1.7	1.7	1.8	1.8	1.8	1.8
1.3	1.7	1.7	1.7	1.7	1.7	1.8	1.8	1.8	1.8	1.8
1.4	1.7	1.7	1.7	1.7	1.7	1.8	1.8	1.8	1.9	1.9
1.5	1.7	1.7	1.7	1.7	1.8	1.8	1.8	1.9	1.9	1.9
1.6	1.7	1.7	1.7	1.8	1.8	1.8	1.9	1.9	1.9	1.9
1.7	1.7	1.7	1.7	1.8	1.8	1.9	1.9	1.9	1.9	1.9
1.8	1.7	1.7	1.8	1.8	1.8	1.9	1.9	1.9	1.9	1.9

Plate thickness s	Tapping hole diameter d_b for thread size ST 2.9									
	Material strength R_m N/mm ²									
	100	150	200	250	300	350	400	450	500	
1.1	2.2	2.2	2.2	2.2	2.2	2.2	2.2	2.2	2.2	2.2
1.2	2.2	2.2	2.2	2.2	2.2	2.2	2.2	2.2	2.2	2.3
1.3	2.2	2.2	2.2	2.2	2.2	2.2	2.2	2.3	2.3	2.3
1.4	2.2	2.2	2.2	2.2	2.2	2.2	2.3	2.3	2.4	2.4
1.5	2.2	2.2	2.2	2.2	2.2	2.3	2.3	2.4	2.4	2.4
1.6	2.2	2.2	2.2	2.2	2.3	2.3	2.4	2.4	2.4	2.4
1.7	2.2	2.2	2.2	2.2	2.3	2.4	2.4	2.4	2.4	2.4
1.8	2.2	2.2	2.2	2.3	2.3	2.4	2.4	2.4	2.5	2.5
1.9	2.2	2.2	2.2	2.3	2.4	2.4	2.4	2.5	2.5	2.5
2.0	2.2	2.2	2.3	2.3	2.4	2.4	2.5	2.5	2.5	2.5
2.2	2.2	2.2	2.3	2.4	2.4	2.5	2.5	2.5	2.5	2.5

Plate thickness s	Tapping hole diameter d_b for thread size ST 3.5									
	Material strength R_m N/mm ²									
	100	150	200	250	300	350	400	450	500	
1.3	2.6	2.6	2.6	2.6	2.6	2.6	2.7	2.7	2.7	2.8
1.4	2.7	2.7	2.7	2.7	2.7	2.7	2.7	2.8	2.8	2.8
1.5	2.7	2.7	2.7	2.7	2.7	2.7	2.8	2.8	2.9	2.9
1.6	2.7	2.7	2.7	2.7	2.7	2.7	2.8	2.9	2.9	2.9
1.7	2.7	2.7	2.7	2.7	2.7	2.8	2.8	2.9	2.9	2.9
1.8	2.7	2.7	2.7	2.7	2.8	2.8	2.9	2.9	2.9	2.9
1.9	2.7	2.7	2.7	2.7	2.8	2.9	2.9	2.9	2.9	3.0
2.0	2.7	2.7	2.7	2.8	2.9	2.9	2.9	3.0	3.0	3.0
2.2	2.7	2.7	2.8	2.8	2.9	3.0	3.0	3.0	3.0	3.0
2.5	2.7	2.7	2.9	2.9	3.0	3.0	3.0	3.1	3.1	3.1
2.8	2.7	2.8	2.9	3.0	3.0	3.0	3.1	3.1	3.1	3.1

Plate thickness s	Tapping hole diameter d_b for thread size ST 3.9									
	Material strength R_m N/mm ²									
	100	150	200	250	300	350	400	450	500	
1.3	2.9	2.9	2.9	2.9	2.9	2.9	3.0	3.0	3.1	3.1
1.4	2.9	2.9	2.9	2.9	2.9	3.0	3.1	3.1	3.1	3.1
1.5	3.0	3.0	3.0	3.0	3.0	3.0	3.1	3.1	3.2	3.2
1.6	3.0	3.0	3.0	3.0	3.0	3.1	3.1	3.2	3.2	3.3
1.7	3.0	3.0	3.0	3.0	3.1	3.1	3.2	3.2	3.3	3.3
1.8	3.0	3.0	3.0	3.0	3.1	3.2	3.2	3.3	3.3	3.3
1.9	3.0	3.0	3.0	3.1	3.2	3.2	3.3	3.3	3.3	3.3
2.0	3.0	3.0	3.0	3.1	3.2	3.2	3.3	3.3	3.3	3.3
2.2	3.0	3.0	3.1	3.2	3.2	3.3	3.3	3.3	3.3	3.4
2.5	3.0	3.0	3.2	3.3	3.3	3.3	3.4	3.4	3.4	3.4
2.8	3.0	3.2	3.3	3.3	3.4	3.4	3.4	3.4	3.4	3.4
3.0	3.0	3.2	3.3	3.3	3.4	3.4	3.4	3.4	3.4	3.5

Plate thickness s	Tapping hole diameter d_b for thread size ST 4.2									
	Material strength R_m N/mm ²									
	100	150	200	250	300	350	400	450	500	
1.4	3.1	3.1	3.1	3.1	3.1	3.1	3.2	3.3	3.4	3.4
1.5	3.2	3.2	3.2	3.2	3.2	3.2	3.2	3.3	3.4	3.4
1.6	3.2	3.2	3.2	3.2	3.2	3.2	3.3	3.4	3.4	3.4
1.7	3.2	3.2	3.2	3.2	3.2	3.3	3.3	3.4	3.4	3.4
1.8	3.2	3.2	3.2	3.2	3.3	3.3	3.4	3.4	3.5	3.5
1.9	3.2	3.2	3.2	3.2	3.3	3.4	3.4	3.4	3.5	3.5
2.0	3.2	3.2	3.2	3.3	3.4	3.4	3.5	3.5	3.5	3.5
2.2	3.2	3.2	3.2	3.3	3.4	3.5	3.5	3.5	3.5	3.6
2.5	3.2	3.2	3.4	3.4	3.5	3.5	3.6	3.6	3.6	3.6
2.8	3.2	3.3	3.4	3.5	3.6	3.6	3.6	3.6	3.6	3.6
3.0	3.2	3.4	3.5	3.5	3.6	3.6	3.6	3.6	3.6	3.7
3.5	3.3	3.5	3.6	3.6	3.7	3.7	3.7	3.7	3.7	3.7

		Tapping hole diameter d_b for thread size ST 4.8								
Plate thickness s	Material strength R_m N/mm ²									
	100	150	200	250	300	350	400	450	500	
1.6	3.6	3.6	3.6	3.6	3.6	3.7	3.8	3.9	3.9	
1.7	3.6	3.6	3.6	3.6	3.7	3.8	3.9	3.9	4.0	
1.8	3.6	3.6	3.6	3.6	3.8	3.8	3.9	4.0	4.0	
1.9	3.6	3.6	3.6	3.7	3.8	3.9	3.9	4.0	4.0	
2.0	3.6	3.6	3.6	3.8	3.9	3.9	4.0	4.0	4.1	
2.2	3.6	3.6	3.7	3.9	3.9	4.0	4.0	4.1	4.1	
2.5	3.6	3.7	3.9	4.0	4.0	4.1	4.1	4.1	4.2	
2.8	3.6	3.8	4.0	4.0	4.1	4.1	4.2	4.2	4.2	
3.0	3.7	3.9	4.0	4.1	4.1	4.2	4.2	4.2	4.2	
3.5	3.8	4.0	4.1	4.2	4.2	4.2	4.2	4.2	4.2	
4.0	4.0	4.1	4.2	4.2	4.2	4.2	4.3	4.3	4.3	

		Tapping hole diameter d_b for thread size ST 8								
Plate thickness s	Material strength R_m N/mm ²									
	100	150	200	250	300	350	400	450	500	
2.1	6.3	6.3	6.3	6.3	6.5	6.6	6.7	6.8	6.9	
2.2	6.3	6.3	6.3	6.5	6.6	6.8	6.8	6.9	7.0	
2.5	6.3	6.3	6.5	6.7	6.8	6.9	7.0	7.0	7.1	
2.8	6.3	6.4	6.7	6.8	6.9	7.0	7.1	7.1	7.2	
3.0	6.3	6.5	6.8	6.9	7.0	7.1	7.1	7.2	7.2	
3.5	6.4	6.8	7.0	7.1	7.1	7.2	7.2	7.3	7.3	
4.0	6.7	6.9	7.1	7.2	7.2	7.3	7.3	7.3	7.3	
4.5	6.8	7.1	7.2	7.2	7.3	7.3	7.3	7.3	7.4	
5.0	7.0	7.1	7.2	7.3	7.3	7.3	7.4	7.4	7.4	
5.5	7.1	7.2	7.3	7.3	7.3	7.4	7.4	7.4	7.4	
6.0	7.1	7.2	7.3	7.3	7.4	7.4	7.4	7.4	7.4	
6.5	7.2	7.3	7.3	7.4	7.4	7.4	7.4	7.4	7.4	

		Tapping hole diameter d_b for thread size ST 5.5								
Plate thickness s	Material strength R_m N/mm ²									
	100	150	200	250	300	350	400	450	500	
1.8	4.2	4.2	4.2	4.2	4.3	4.4	4.5	4.6	4.6	
1.9	4.2	4.2	4.2	4.2	4.4	4.5	4.6	4.6	4.7	
2.0	4.2	4.2	4.2	4.3	4.4	4.5	4.6	4.6	4.7	
2.2	4.2	4.2	4.3	4.4	4.5	4.6	4.7	4.7	4.8	
2.5	4.2	4.2	4.4	4.6	4.7	4.7	4.8	4.8	4.8	
2.8	4.2	4.4	4.6	4.7	4.7	4.8	4.8	4.8	4.9	
3.0	4.2	4.5	4.6	4.7	4.8	4.8	4.8	4.9	4.9	
3.5	4.4	4.6	4.7	4.8	4.8	4.9	4.9	4.9	4.9	
4.0	4.6	4.7	4.8	4.9	4.9	4.9	4.9	5.0	5.0	
4.5	4.7	4.8	4.9	4.9	4.9	4.9	5.0	5.0	5.0	

		Tapping hole diameter d_b for thread size ST 6.3								
Plate thickness s	Material strength R_m N/mm ²									
	100	150	200	250	300	350	400	450	500	
1.8	4.9	4.9	4.9	4.9	5.0	5.2	5.3	5.3	5.4	
1.9	4.9	4.9	4.9	5.0	5.1	5.2	5.3	5.4	5.4	
2.0	4.9	4.9	4.9	5.1	5.2	5.3	5.4	5.4	5.5	
2.2	4.9	4.9	5.0	5.2	5.3	5.4	5.5	5.5	5.6	
2.5	4.9	5.0	5.2	5.4	5.4	5.5	5.6	5.6	5.6	
2.8	4.9	5.2	5.3	5.5	5.5	5.6	5.6	5.7	5.7	
3.0	4.9	5.3	5.4	5.5	5.6	5.7	5.7	5.7	5.7	
3.5	5.2	5.4	5.5	5.6	5.7	5.7	5.7	5.7	5.8	
4.0	5.3	5.5	5.6	5.7	5.7	5.7	5.8	5.8	5.8	
4.5	5.5	5.6	5.7	5.7	5.8	5.8	5.8	5.8	5.8	
5.0	5.5	5.7	5.7	5.8	5.8	5.8	5.8	5.8	5.8	

9.3.2 Thread for tapping screws

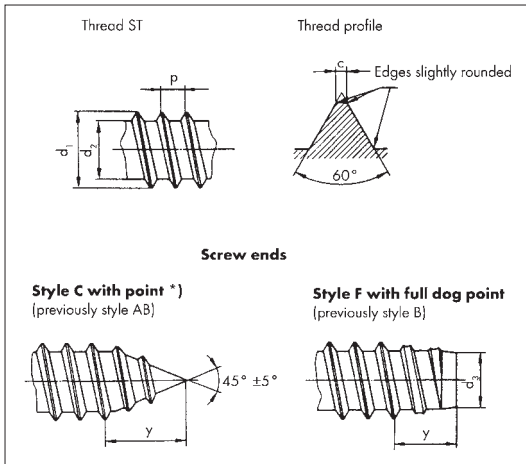

The dimensions for tapping screws such as pitch and diameter are shown in table 48 for ST 1.5 to ST 9.5.

Thread size		ST 1.5	ST 1.9	ST 2.2	ST 2.6	ST 2.9	ST 3.3	ST 3.5
P	≈	0.5	0.6	0.8	0.9	1.1	1.3	1.3
d ¹	max.	1.52	1.90	2.24	2.57	2.90	3.30	3.53
	min.	1.38	1.76	2.1	2.43	2.76	3.12	3.35
d ₂	max.	0.91	1.24	1.63	1.90	2.18	2.39	2.64
	min.	0.84	1.17	1.52	1.80	2.08	2.29	2.51
d ₃	max.	0.79	1.12	1.47	1.73	2.01	2.21	2.41
	min.	0.69	1.02	1.37	1.60	1.88	2.08	2.26
c	max.	0.1	0.1	0.1	0.1	0.1	0.1	0.1
y	Style C	1.4	1.6	2	2.3	2.6	3	3.2
Aux. dimension	Style F	1.1	1.2	1.6	1.8	2.1	2.5	2.5
Number		0	1	2	3	4	5	6

Thread size		ST 3.9	ST 4.2	ST 4.8	ST 5.5	ST 6.3	ST 8	ST 9.5
P	≈	1.3	1.4	1.6	1.8	1.8	2.1	2.1
d ¹	max.	3.91	4.22	4.8	5.46	6.25	8	9.65
	min.	3.73	4.04	4.62	5.28	6.03	7.78	9.43
d ₂	max.	2.92	3.10	3.58	4.17	4.88	6.20	7.85
	min.	2.77	2.95	3.43	3.99	4.70	5.99	7.59
d ₃	max.	2.67	2.84	3.30	3.86	4.55	5.84	7.44
	min.	2.51	2.69	3.12	3.68	4.34	5.64	7.24
c	max.	0.1	0.1	0.15	0.15	0.15	0.15	0.15
y	Style C	3.5	3.7	4.3	5	6	6.5	8
Aux. dimension	Style F	2.7	2.8	3.2	3.6	3.6	4.2	4.2
Number		7	8	10	12	14	16	20